

机器人自动快换 ROBOT AUTOMATIC QUICK CHANGER

OQC-060S(带传感器)机器人自动快换 OQC-060S Robot automatic quick changer (with sensor)

- 载重60kg;
 - 采用钢球锁紧方式;
 - 具有防尘功能;
 - 采用机械式自锁设计;
 - 防止气源意外切断时两侧分离;
 - 可选配PNP或NPN传感器。
- Payload capacity 60 kg;
 - Steel ball lock system;
 - With dustproof function;
 - Adopt the mechanical self-locking design;
 - Prevent separation from separating when when source of cut off0;
 - PNP or NPN sensor is available.

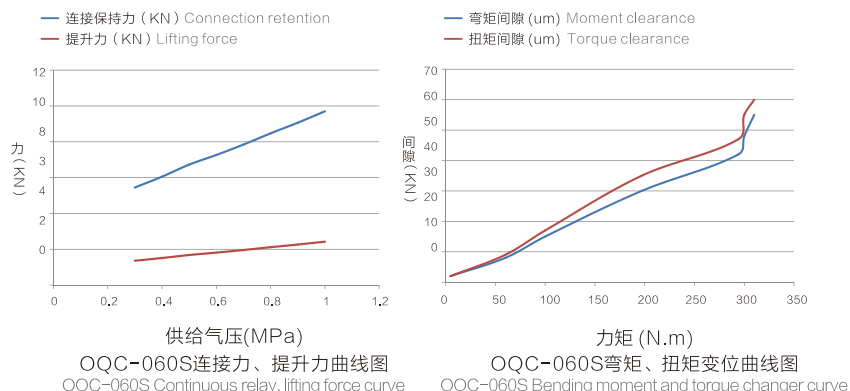
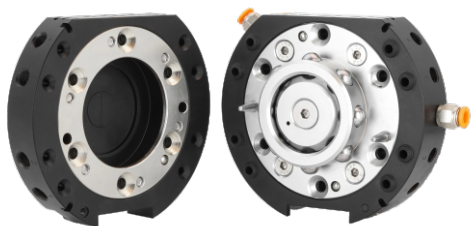

规格参数 Specifications

本体部分 Mainbody	可搬运重量(额定负载)Payload capacity	60kg	
	位置重复精度 Positon repeatability	± 0.02mm	
	静态允许力矩 Static allowable torque	弯矩方向 Bending direction(Mx.My)	197N.m
		扭矩方向 Torque direction(Mr)	294N.m
	锁紧力 (当气压 0.49Mpa时)Tight locking force (When the air pressure is 0.49Mpa)	6726N	
	材质 Material	本体 Main body	铝合金 Aluminum alloy
		锁紧机构部分 Locking mechanism	合金钢 Alloy steel
	外形尺寸(锁紧时Lock) Housing diameter(Lock when locked)	Φ 130mmxH54mm	
	产品重量 Product weight	机器人侧 Robot side	1.43kg
		工具侧 Tool side	0.7kg
拆装结构 Disassembling institutions	钢球定位锁紧 Steel ball position lock		
拆装动作气压 Disassembling action pressure	0.39~0.7MPa(4~7kgf/cm ²)		
允许温度与湿度范围 Allowable temperature and humidity range	0~55℃, 0~95%(不结露No condensation)		
通用 General	通气孔 Pneumatic port	G1/8 x8个	
组件 Component (选配 Option)	通用 General	电信号点 Electrical signal	2A x12PIN/2A x23PIN/2A x8PIN

模块安装说明 MODULE INSTALLATION DESCRIPTION

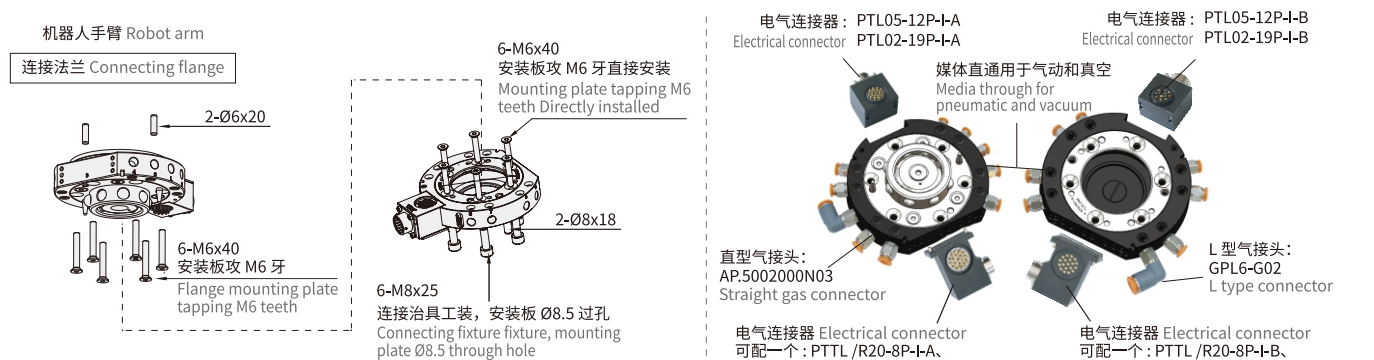

▶ 外形尺寸 OVERALL DIMENSIONS

机器人侧: OQC-060S-A

Robot side

订货编号: 7.03.01.0017

Order number

单价:

Price

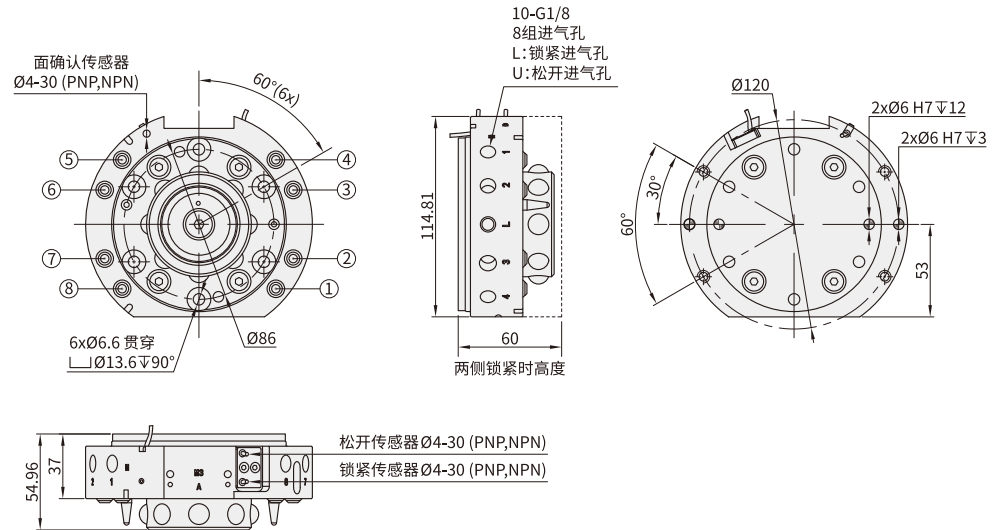

工具侧: OQC-060-B

Tool side

订货编号: 7.03.01.0018

Order number

单价:

Price

